

APX SERIES

COLD PLANERS

Operating and Maintenance Manual



TABLE OF CONTENTS

1. PRODUCT WARRANTY	3
2. CHECKLIST Dealer's File Copy	4
Customer's File File.....	5
3. INTRODUCTION	6
4. SPECIFICATIONS	7
5. SAFETY	8
5.1 Mandatory Safety Shutdown Procedure.....	9-10
6. OPERATION	11
6.1 Forward	11
6.2 Attaching to and detaching from skidsteer loader	11
6.3 Preparing to Plane.....	12
6.4 Starting the Cut.....	12
6.5 Advancing the Cut.....	13
6.6 Ending the Cut.....	13
7. DAILY MAINTENANCE	14
7.1 Pic Removal and Replacement.....	15
7.2 Removal.....	15
7.3 Replacement	16
7.4 Changing a Drum	17
8. PARTS	18
APX Planer Drawings.....	18-19
APX Planer Parts List.....	20-21
4-Line Hydraulic Drawing & Parts List.....	22-23
2-Line Hydraulic Drawing & Parts List	24-25
4-Line Hydraulic W/Tilt Drawing & Parts List.....	26-27
2-Line Hydraulic W/Tilt Drawing & Parts List.....	28-29
Swingaway Arm Drawing & Parts List.....	30
Host Kits.....	31-34
Danfoss Motor Parts List.....	35

1. PRODUCT WARRANTY

PRODUCT



WARRANTY

PURPOSE OF POLICY

The policy covers correction of defects in workmanship and/or materials called to the attention of Coneqtec/Universal and is subject to all conditions of the warranty.

STATEMENT OF WARRANTY

Coneqtec/Universal warrants its products for up to one year from the purchase date when correctly used under normal operating conditions. Coneqtec/Universal makes no other warranty expressed or implied.

This warranty shall not apply to any products that have been altered, changed or repaired in any manner whatsoever. Nor shall it apply to any product which has been subject to misuse, negligence or accident.

The exclusive and sole remedy for breach of contract (including breach of any express or implied warranty) shall be limited to repair, modification or replacement at the sole discretion of Coneqtec/Universal, of non-conforming products as aforesaid. Coneqtec/Universal shall not in any event be liable to anyone. Faulty or suspect parts must be returned to Coneqtec/Universal at user's cost.

GENERAL

Coneqtec/Universal reserves the right to make changes or improvements in design or construction of any part without incurring the obligation to install such changes on any unit previously delivered.

WARRANTY PARTS & LABOR PROCEDURES

WARRANTY PARTS & LABOR POLICY

Warranty parts credits will be allowed for the replacement parts that prove in the company's judgment to be defective in material or workmanship on machines sold to the original purchaser. No consideration whatsoever will be made on used, second-hand, altered or rebuilt machinery.

Only genuine Coneqtec/Universal parts will be used in correction of defective products. Any parts used that are not of Coneqtec/Universal origin will not be warranted unless prior Coneqtec/Universal approval has been granted.

Warranty labor will be paid at \$40 per hour based on flat rates established by Coneqtec/Universal; however, no mileage or mileage time will be reimbursed.

Warranty will not be paid if the dealer is not capable of doing the testing that is required by Coneqtec/Universal (this pertains to hydraulic testing and the use of pressure testing equipment) to determine the location or source of the problem.

OWNER RESPONSIBILITY

Every owner is responsible for the machine's proper use and maintenance. Parts that are simply worn out through normal wear and tear, or abused or damaged due to lack of maintenance or adjustment are not subject for warranty consideration.

DEALER RESPONSIBILITY

Coneqtec/Universal requires that the dealership has a service center that is staffed and has the ability to setup and do pre-delivery on all units prior to delivery and to do testing that is required by Coneqtec/Universal in the event that there is a problem with the machine.

It is also required that the dealers instruct the customer on the proper operation and safety procedures.

WARRANTY PROCEDURE

Warranty will not be considered on the following unless it can be proved there is negligence in workmanship or materials.

Wear items such as pics, pic blocks, blades and cutters.

Hoses that have been worn or damaged by use.

PROCEDURE FOR CLAIM

Prior to starting any warranty work please call Coneqtec/Universal for approval and notification of flat rate allowances. All warranty claims must be received within thirty days of warranty repair in order to be a valid warranty claim. Otherwise warranty claim will be denied. A copy of the parts invoices and shop work orders must be submitted with the warranty form, and the form must be filled out completely with all customer and machine information. The warranty/RGA form with parts should then be sent to the designated location stated on form. Coneqtec/Universal will pay only standard Fed Ex or LTL truck freight on warranty items.

All warranty credits will be applied to the dealer's account.

Revised 11/1/01

P.O. BOX 9102 • WICHITA, KS 67277 • (888) 832-3462 • Fax (316) 946-5552

2. CHECKLIST

DEALER'S FILE COPY

2.1 PRE-DELIVERY

After the Cold Planer has been completely set up and attached to the host machine, inspect the following. Check off each item after the prescribed action is taken.

Check that:

- ◆ No parts of the unit have been damaged in shipment. Check for things such as dents and loose or missing parts; correct or replace components as required.
- ◆ All bolts and fasteners are in place and tightly secured.
- ◆ All grease fittings have been properly lubricated; see lubrication information in this manual.
- ◆ All decals are in place and securely attached.
- ◆ The serial number of your unit is recorded in the space provided on this page.
- ◆ Then, test run the unit while checking that all components are operating correctly.

I acknowledge that the procedures were performed on this unit as outlined above.

DEALERSHIP NAME

DEALER REPRESENTATIVE'S NAME

DATE CHECKLIST FILLED OUT

SERIAL NUMBER

2.2 DELIVERY

The following checklist is an important reminder of the valuable information that **MUST** be passed on to the customer at the time the unit is delivered. Check off each item as you explain it to the customer.

- ◆ Give the customer his operators manual. Instruct him to be sure to read and completely understand its contents **BEFORE** operating the unit.
- ◆ Explain and review with him the **SAFETY** information in this manual.
- ◆ Explain that regular cleaning and lubrication are required for proper operation and long life. Review with him the lubrication information in this manual.
- ◆ Explain and review with him the service & maintenance information in this manual.
- ◆ Completely fill out the owner's registration, including the customer's signature, and return it to the manufacturer.

I acknowledge that the above points were reviewed with me at the time of delivery.

CUSTOMER'S SIGNATURE

DATE DELIVERED

2. CHECKLIST

CUSTOMER'S FILE COPY

2.1 PRE-DELIVERY

After the Cold Planer has been completely set up and attached to the host machine, inspect the following. Check off each item after the prescribed action is taken.

Check that:

- ◆ No parts of the unit have been damaged in shipment. Check for things such as dents and loose or missing parts; correct or replace components as required.
- ◆ All bolts and fasteners are in place and tightly secured.
- ◆ All grease fittings have been properly lubricated; see lubrication information in this manual.
- ◆ All decals are in place and securely attached.
- ◆ The serial number of your unit is recorded in the space provided on this page.
- ◆ Then, test run the unit while checking that all components are operating correctly.

I acknowledge that the procedures were performed on this unit as outlined above.

DEALERSHIP NAME

DEALER REPRESENTATIVE'S NAME

DATE CHECKLIST FILLED OUT

SERIAL NUMBER

2.2 DELIVERY

The following checklist is an important reminder of the valuable information that **MUST** be passed on to the customer at the time the unit is delivered. check off each item as you explain it to the customer.

- ◆ Give the customer his operator's manual. Instruct him to be sure to read and completely understand its contents **BEFORE** operating the unit.
- ◆ Explain and review with him the **SAFETY** information in this manual.
- ◆ Explain that regular cleaning and lubrication are required for proper operation and long life. Review with him the lubrication information in this manual.
- ◆ Explain and review with him the service & maintenance information in this manual.
- ◆ Completely fill out the owner's registration, including the customer's signature and return it to the manufacturer.

I acknowledge that the above points were reviewed with me at the time of delivery.

CUSTOMER'S SIGNATURE

DATE DELIVERED

3. INTRODUCTION

The **APX SERIES COLD PLANER** was designed as an attachment machine for use on skidsteer loaders. The information contained in this manual refers only to the planer machine. Information regarding the valves used to control oil flow to the planer attachment can be found in the host machines manual.

The information contained within is provided to assist you in preparing, adjusting, maintaining, and servicing your machine. More importantly, this manual provides an operating plan for safe and proper use of your machine. Major points of safe operation are detailed in the safety chapter of this manual. Refer to the table of contents for an outline of this manual.

Modern machinery has become more sophisticated, and with that in mind, you must read and understand the contents of the manual **COMPLETELY** and become familiar with your new machine before attempting to operate it.

Terms such as “right” and “left” as used in the manual, are as though the reader is sitting in the host machine’s operator seat and facing the planer.

Throughout this manual, information is provided which is set in bold type and introduced by the word **NOTE**. Be sure to read carefully and comply with the message or directive given. Following this information will improve your operating or maintenance efficiency, help you to avoid costly breakdowns or unnecessary damage, and extend the life of your machine.

The Manufacturer and Society of Automotive Engineers have adopted this **SAFETY ALERT SYMBOL** to pinpoint characteristics that, if not properly followed, can create a safety hazard. When you see this symbol in this manual or on the unit itself, you are reminded to **BE ALERT! YOUR SAFETY IS INVOLVED!**



The manufacturer reserves the right to make changes or improvements in the design or construction of any part without the obligation to install such changes on any unit previously delivered.

4. SPECIFICATIONS

APX SERIES

MODEL	STANDARD DRUM WIDTH
APX-300.....	12 Inches (300 mm)
APX-400.....	16 Inches (400 mm)
APX-450.....	18 Inches (450 mm)
APX-600.....	24 Inches (600 mm)

MAXIMUM TILT ANGLE 15 degrees left & right

SIDE SHIFT TRAVEL 24 inches (610 mm)

WEIGHT*

APX300	1200 lbs. (544 kg)
APX400	1500 lbs. (680 kg)
APX450	1600 lbs. (726 kg)
APX600	1700 lbs. (771 kg)

* Weights are for fully hydraulic planers equipped for use on skidsteer loaders and are approximate due to optional equipment.

5. SAFETY

BEFORE YOU ATTEMPT TO OPERATE THIS EQUIPMENT, READ AND STUDY THE FOLLOWING SAFETY INFORMATION. IN ADDITION, MAKE SURE THAT EVERY INDIVIDUAL WHO OPERATES OR WORKS WITH THIS EQUIPMENT IS FAMILIAR WITH THESE SAFETY PRECAUTIONS.



The manufacturer always takes the operator and their safety into consideration when designing machinery. Guards are provided on exposed moving parts for the operator's protection; however, some areas cannot be guarded or shielded in order to assure proper operation. In addition, the operator's manual and decals on the machine itself warn you of further danger and should be read and observed closely.

The **SAFETY ALERT SYMBOL** above means **ATTENTION! BECOME ALERT! YOUR SAFETY IS INVOLVED!** It stresses an attitude of **"HEADS UP"** for safety and can be found throughout this operator's manual and on the unit itself.

REMEMBER: The careful operator is the best operator. Most accidents are caused by human error. Certain precautions must be observed to prevent the possibility of injury or damage.

Please read the rules listed below for safe operation **BEFORE** you operate this equipment.

Use of words **CAUTION**, **WARNING**, or **DANGER** herein and on the machine itself signal three degrees of hazard.

CAUTION is used for general reminders of good safety practices or to direct attention to unsafe practices.

WARNING is used to denote a specific potential hazard.

DANGER is used to denote the most serious specific potential hazard.

5.1 MANDATORY SAFETY SHUTDOWN

Work of any type on machinery is always more dangerous when the machine is operating. **BEFORE** cleaning, lubricating, or servicing this unit, the following **MANDATORY SAFETY SHUTDOWN PROCEDURE** should **ALWAYS** be followed:

1. Move host machine's propulsion control to the neutral position and idle engine down.
2. Shut off cold planer.
3. Position cold planer so that it is completely resting on the ground or floor.
4. Engage the host machine's hand brake.
5. Move the host machine's throttle to the slow idle position, shut the engine off, and remove the ignition key.
6. Relieve hydraulic pressure by moving the hi-flow and cylinder control levers in both directions.

ONLY when you have taken these precautions can you be sure it is safe to proceed. Failure to follow the above procedures could lead to death or serious bodily injury!

Some diagrams used herein may show door(s), guard(s), or shield(s) open or removed for illustration purposes **ONLY! BE SURE** that all door(s), guard(s), and shield(s) are in their proper position(s) and securely attached **BEFORE** operating the planer!

Read and observe **ALL** safety information and decals on the host machine and cold planer **BEFORE** operating the unit! In addition, familiarize yourself with **ALL** of the safety devices and periodically check that they are functioning properly!

Refer to the **SAFETY** chapter of the host machine's operator manual and observe **ALL** safety recommendations set forth in that manual!

CAREFULLY inspect **ALL** hydraulic hoses and connections on a routine basis. **NEVER** use your hand; escaping fluid under pressure can cause serious injury!



BE SURE to exercise the **MANDATORY SAFETY SHUT DOWN PROCEDURE BEFORE** proceeding to do any work on the cold planer!

BE SURE the cold planer is properly placed in the “service position” and resting on the ground **BEFORE** attempting to work on the drum.

BEFORE transporting the cold planer, **BE SURE** to raise the unit completely off the ground and turn it off.

When replacing pics, **BE SURE** to use only a soft or lead headed hammer when inserting the pics into the holders.

ALWAYS wear safety glasses with side shields when striking metal against metal! In addition, it is recommended that a softer (non-chipable) material be used to cushion the blow. Failure to heed could result in serious injury to the eyes or other parts of the body!

ALWAYS wear proper clothing and covering when working with or on the cold planer!

DO NOT attempt to move the cold planer sideways while it is on the ground!

DO NOT attempt to work on the planer or host machine with the hydraulics live! **BE SURE** to relieve the hydraulic pressure by shutting down the engine and moving all control levers **BEFORE** attempting to disconnect any hoses or **BEFORE** proceeding to remove the cold planer from the host machine.

DO NOT treat the cold planer like a bucket; it can be damaged by contact with solid objects as well as upset the stability of the host machine!

DO NOT hit the pics with a steel hammer as this could cause steel chips to fly, causing injury to the eyes or face.

REMEMBER! It is the owner’s responsibility to communicate information regarding the safe use and proper operation and maintenance to any user of this machine!

6. OPERATION

6.1 FOREWORD

The planer must be attached to a host machine equipped to provide the necessary hydraulics and operational controls. As there are many different host machines available, this manual will only deal with the generic operation of the planer. Anyone attempting to attach and operate the planer must first have the knowledge and skill of operating the host machine's controls. Information regarding the host machine's controls and attaching procedure is found in the host machine's operators manual or from its authorized dealer.

6.2 ATTACHING TO AND DETACHING FROM A SKIDSTEER LOADER

Drive the skidsteer up to the quick attach of the planer and connect up. Exercise the **MANDATORY SAFETY SHUTDOWN PROCEDURE** before proceeding. After installing hydraulic quick couplers compatible with your skidsteer to the hydraulic hoses of the planer, connect them to the hydraulic outlet as follows:

1. If your skidsteer has five lines i.e. (2 high flow , 2 auxiliary, and 1 case drain):

The 3/4" hose attached to the # "2" port of the overrunning valve must be connected to the pressure outlet of the skidsteer's high flow. The 3/4" hose attached to the # "1" port must be connected to the return outlet. The two 1/4" hoses must be connected to the skidsteer's auxiliary outlets. The 3/8" case drain line must be connected to the skidsteer's case drain outlet.

2. If your skidsteer has 3 lines i.e. (2 high flow lines, and 1 case drain):

The 3/4" hose attached to the "C" port of the selector valve must be connected to the pressure outlet of the skidsteer, and the 3/4" hose attached to the "D" port of the selector valve to the return outlet. The 3/8" case drain line must be attached to the skidsteer's case drain outlet.

3. On APX 300 planers on standard flow skidsteer's without a case drain, connect as per "2" but omit the case drain connection.

6.3 PREPARING TO PLANE

Check the surface to be planed. The standard drum for each model can be used to mill both asphalt and concrete. If a finer finish is required, drums with more pics are available. Contact Coneqtec/Universal for special drums.

Determine the required depth of cut, tilt angle of cut, and left to right position of the planer in regard to the host machine.

When it is safe to do so, start the host machine's engine, and ensure that the planer drum is not touching the ground. This is accomplished by rolling the bucket control back. Turn on the planer, and check the drum rotation. The teeth at the bottom of the drum must be moving in the same direction that the planer travels over the material to be planed. If the drum rotates incorrectly, correct the planer installation before attempting to plane. In skidsteer operation, only forward travel should be used.

On standard planers the tilt angle is adjusted by simply turning the manual turnbuckle. If the planer is equipped with the optional hydraulic tilt, move the selector valve lever to the correct position, and tilt the planer using the skidsteer's auxiliary hydraulic control.

A hydraulic cylinder holds the planer in position on the mounting plate slide. Move the selector valve lever to the correct position, and move the planer to the required position using the skidsteer's auxiliary hydraulic control.

6.4 STARTING THE CUT

Position the planer over the desired starting place. With the planer turned on, the depth gauge at "0" and the host machine's engine at full rpm, slowly lower the planer to the surface to be planed until the weight of the planer is resting on the planer's wheels. The APX Planer's cutting depth is controlled by the skidsteer's bucket roll. Rolling it forward increases the drum depth, and rolling backward decreases the drum depth. The scale on the left side of the planer cowl in relation to the depth control link shows how deep you are cutting. Roll the bucket control forward until the desired depth is reached. Maximum depth of each cut is determined by the type of material being milled, the weight and hydraulic horsepower of the host machine, and the size planer being used. A general rule of thumb is to start at 3/4" to 1" deep in concrete and 1-1/2" to 2" deep in asphalt. As you increase the cutting depth you will also be automatically applying down pressure on the planer. This is necessary to keep the planer stable during planing. For maximum down pressure the skidsteer's front wheels should be 2-3" (50-75 mm) off the planing surface. This can be controlled by raising or lowering the boom arms.

6.5 ADVANCING THE CUT

Advance the planer in the direction the drum pics are traveling in the cut. If the planer drum stalls, you have been feeding the planer into the cut too fast or cutting too deep. Back out of the cut until the drum restarts, and then advance again. If the planer tends to ride up out of the cut, use the procedure outlined in the paragraph above to keep the planer wheels on the surface to be planed.

DO NOT side shift the planer while the drum is in the cut. The drum will not cut in a side to side direction. The depth controls may be actuated while the drum is in the cut.

6.6 ENDING THE CUT

Stop advancing the planer and raise the drum out of the cut by rolling the bucket back. Raise the planer clear out of the pavement, and move to the next cut.



CAUTION: When using cold planers with skidsteer loaders equipped with hi-flow kits, periodic observation must be made of the transmission oil temperature indicator on the skidsteer loader. Hydraulic oil may overheat, depending on ambient temperature and duty cycle of the machine. If indicator comes on or a gauge indicates a temperature in the danger range, shut off cold planer, and allow skidsteer loader to idle until the hydraulic temperature falls below 180°F . **Damage to machine may occur if these instructions are not followed.**

7. DAILY MAINTENANCE



CAUTION: NEVER attempt to do any maintenance to the planer while it is running. Exercise the **MANDATORY SAFETY SHUTDOWN PROCEDURE BEFORE** proceeding.

NOTE: Careful attention to the daily maintenance routines will go a long way toward ensuring efficient planer operation.

1. At the start of each day, lubricate the grease fittings at the end of the carriage arm on each side of the planer housing and the bearing on the right hand side of the drum shaft. Standard shop gun grease will suffice.
2. Check crossslide rods, and tilt plates for lubrication. Clean away any dust or dirt, and apply oil to these areas.

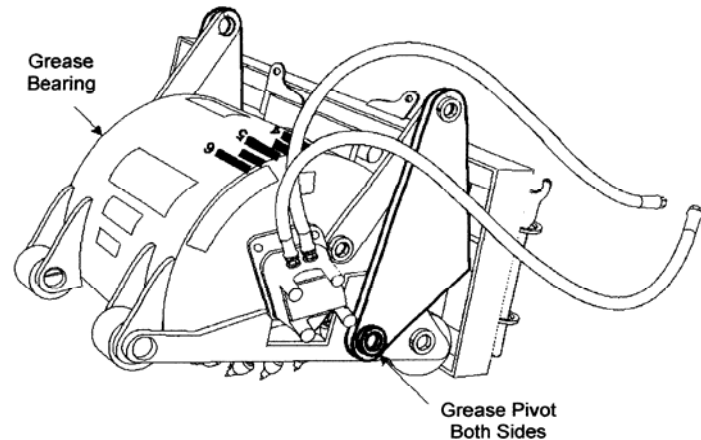

3. Using the correct size wrenches, retighten any loose hardware.
4. Inspect for any loose hydraulic fittings or damaged hoses; retighten or replace as required.
5. At least twice a day check all pics for freedom of rotation and wear. Replace or free up all pics that are not rotating freely, and replace any that are badly worn. Follow the procedure outlined under pic removal and replacement.



WARNING: NEVER use your hands to check for hydraulic leaks. Escaping fluid under pressure can cause serious injury! If injured by escaping fluid, see a doctor at once. If proper medical treatment is **NOT** administered **IMMEDIATELY** serious infection or reaction can develop.

7.1 PIC REMOVAL AND REPLACEMENT

To achieve maximum pic life and optimum performance, the pics will require replacement for the following reasons:

1. They are broken or worn.
2. They are seized in the pic holder and do not rotate freely.

7.2 REMOVAL

To provide access to the pics for inspection or replacement, the APX Planer cowl can be easily turned upside down by the following instructions:

First, be sure to disconnect all hoses between the skidsteer and the planer! Failure to do so can cause damage to these hoses that is not warrantable. After disconnecting all hoses, raise the boom arms, and roll the bucket dump forward, keeping the front wheels of the planer at ground level. Continue until the front wheels, when on the ground will allow the planer cowl to go over center. Lower the boom arms, and roll the bucket dump back until the planer wheels are all on the ground. You now have excellent access to the drum and pics. Be sure to set the skidsteer parking brake and shut its engine down before proceeding.

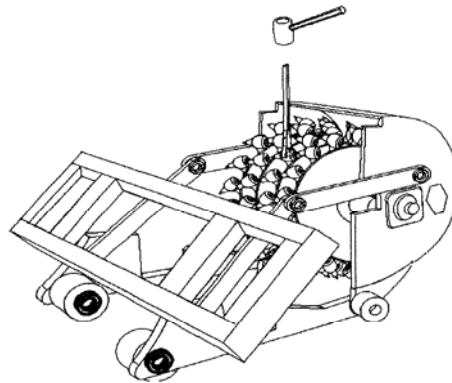

WARNING: When above maneuver is being performed, be sure that no one is in contact with the planer to avoid injury!

1. Rotate the drum until the pic to be removed is conveniently accessible.
2. Hold the pic removal tool in one hand, and place the jaws in the groove of the pic with the offset handle pointing away from the pic holder.
3. Using a lead hammer or rubber-headed mallet, hit the raised pad on the tool until the pic starts to move, and continue to tap it out.

NOTE: If the pic does not have a groove, use a pic punch and a lead hammer or rubber-headed mallet to drive the pic out of the holder from the back side.

7.4 CHANGING A DRUM

To change a drum, position the planer as described in 6.1.1 pic removal.

1. Support the drum at its center with a proper hoist or lifting device.
2. Remove the four cap screws bolting the motor to the planer.
3. Turn the drum until you find a pipe plug in the shaft approximately four inches from the shaft motor end. Remove this plug, and install the necessary bushing and a grease fitting. Using a hand grease gun, pump grease into the shaft to assist in pushing the motor out of the drum shaft.
4. Loosen the set screws locking the bearing center to the shaft. Remove the four nuts and cap screws retaining the outside bearing to the cowl side; remove the bearing.
5. The drum can now be moved out of the cowl. With some models it may be necessary to disconnect the upper end of the bearing side depth control link to allow the drum to be lifted clear of the planer. If this link is removed, be sure to properly support the cowl to avoid injury. Replacing the drum is a reversal of the above. Prior to installing the motor into the shaft bore, remove the grease fitting and bushing. Clean most of the grease from the bore. Clean and inspect the motor shaft and key, install motor, and replace and torque 5/8" capscrews to 175-200 lb. ft.

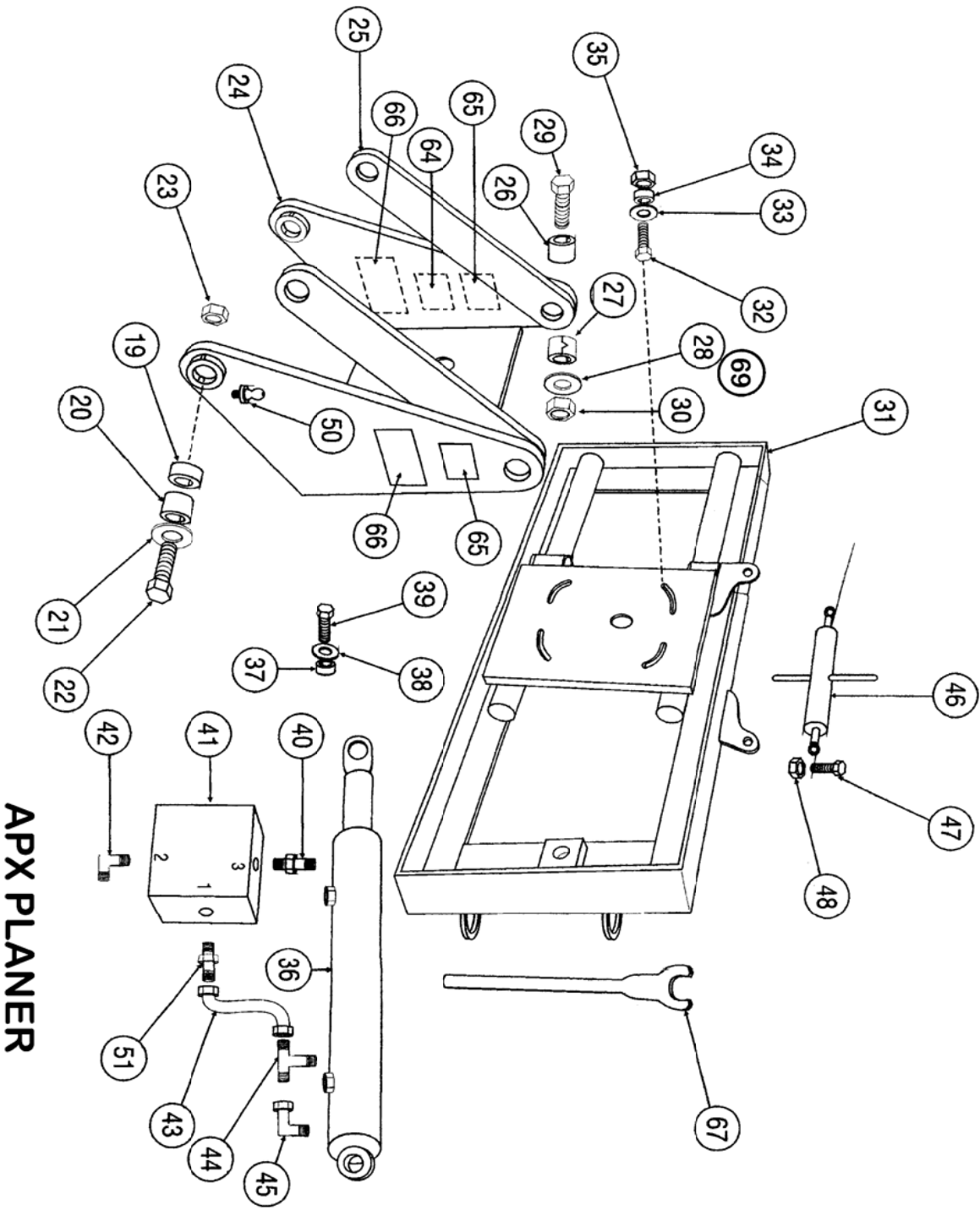

APX PLANER

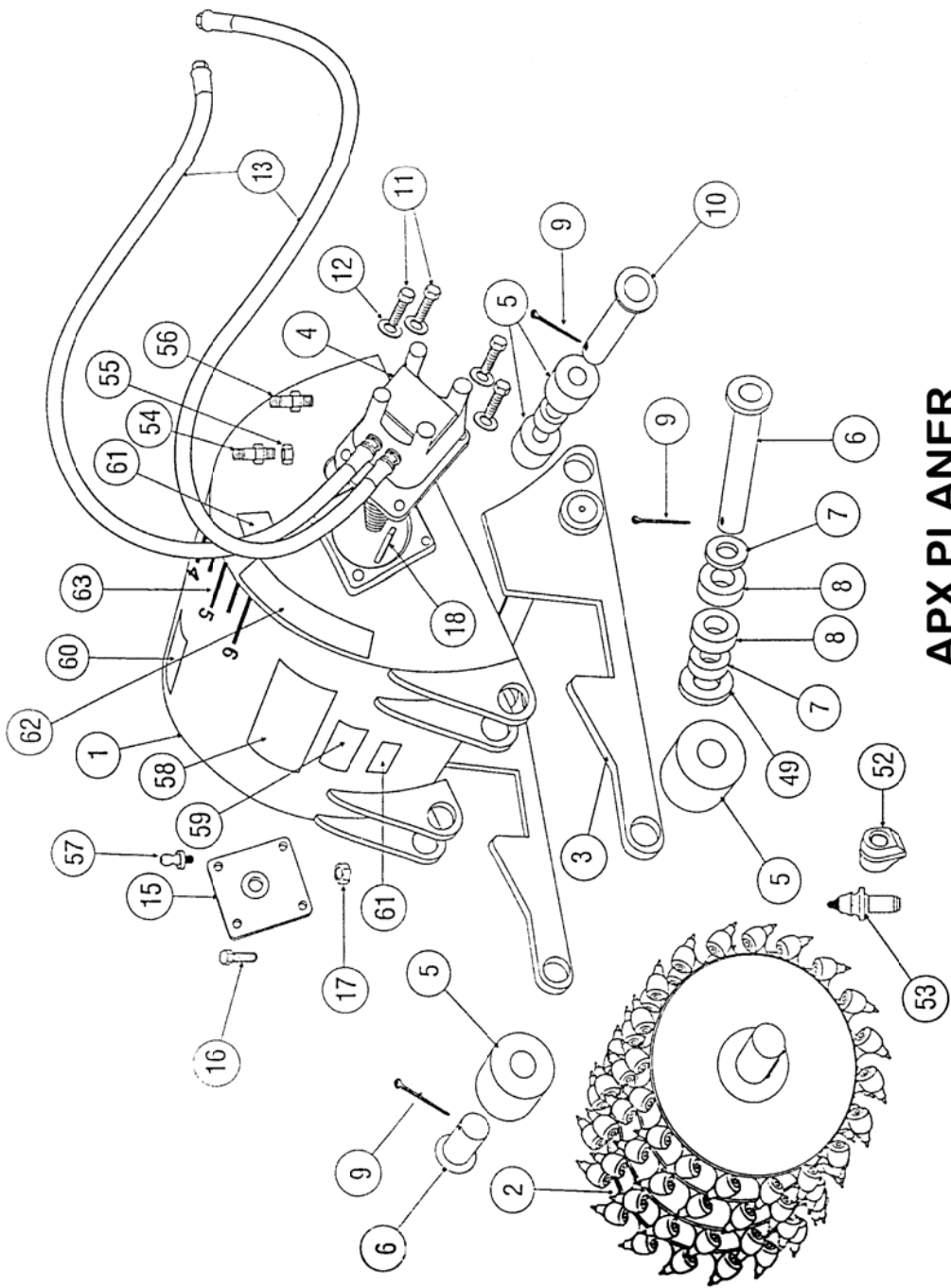

APX PLANER

APX PARTS LIST

ITEM	P/N	DESCRIPTION	QTY
1	55421	Cowl Assy APX 300	1
1	55423	Cowl Assy APX 400/450	1
1	55424	Cowl Assy APX 600	1
2	55451	Drum Assy APX 300	1
2	55400	Drum Assy APX 400	1
2	55452	Drum Assy APX 450	1
2	55453	Drum Assy APX 600	1
3	55425	Trolley Assy APX 300	1
3	55427	Trolley Assy APX 400/450	1
3	55428	Trolley Assy APX 600	1
4	55073	Motor 400CC	1
4	52708	Motor 500CC	1
4	52588	Motor 630CC	1
4	54329	Motor 800CC	1
5	42013	Wheel	6
6	52596	Wheel Axle Front	2
7	42015	Spacer Wheel	14
8	42014	Bearing Wheel	12
9	13A-0640	Cotter Pin 3 3/16 x 2-1/2"	4
10	42016	Wheel Axle Rear	2
11	50A-1012	5/8-11 x 1-1/2" HHCS	4
12	14A-10	5/8 Lock Washer Motor	4
13	54723	Hose 3/4" x 52"	2
15	54958	Bearing	1
16	50A-1018	5/8-11 x 2-1/4"	4
17	30C-10	5/8-11 Nylock Nut	4
18	52681	Key	1
19	42004	Bushing Carriage Pivot (Up to S/N—)	2
19	55545	Bushing S/N—& Up	2
20	55546	Pivot Pin Carriage S/N—& Up	2
20	55415	Pivot Pin Carriage	2
21	55406	Washer 1" Carriage Pivot	2
22	50A-1630	1-8 x 3-3/4" HHCS	2
23	30C-16	1-8 Nylock Nut	2
24	55429	Carriage Assy APX 300	1
24	55431	Carriage Assy APX 400/450	1
24	55432	Carriage Assy APX 600	1
25	55417	Link Depth Control	2
26	55418	Spacer Depth Link	4
27	55416	Bushing Depth Link	4
28	55407	Washer 7/8" Depth Link	4
29	50A-1428	7/8-9 x 3-1/2 HHCS	4
30	30C-14	7/8-9 Nylock Nut	4
31	54089	Crossslide Assy Universal	1
32	50A-1024	5/8-11 x 3" HHCS	4
33	52165	Hardened Washer	4
34	52380	Double Lock Washer Tilt	4
35	30C-10	5/8-11 Nylock Nut Tilt	4

APX PARTS LIST (Cont.)

ITEM	P/N	DESCRIPTION	QTY
36	54064	Cylinder Slide	1
36	55033	Cylinder Seal Kit	AR
37	54991	Bushing Cylinder	2
38	14C-12	3/4" Flat Washer Slide Cylinder	2
39	350A-20050	M20 x 50 HHCS	2
40	111K-0604	Adapter Stir SAEM/NPTM-#3 Lock Valve	1
41	52981	Valve Lock	1
41	54946	Seal Kit 52981 Valve	AR
42	111B-0406	Adapter 90° JICM/SAEN-#2 Lock Valve	1
43	54114	Hose 1/4 x 25" Ppilot	1
44	110Y-04	Adapter Tee JIC/NPT Cyl Base	1
45	112B-04	Adapter 90° JICM/JICF	1
46	55462	Turnbuckle Tilt	1
47	50A-1228	3/4-10 x 3-1/2 HHCS	2
48	30C-12	3/4-10 Nylock Nut	2
49	14C-18	1-1/8" Flat Washer	4
50	29A-02	Grease Fitting	2
51	111E-0406	Adapter Str JIC / SAE	1
52	40028	Pic Block	AR
53	10150	Pic Low Torque	AR
53	10151	Pic Combination	AR
54	111E-1216	Adapter JIC/SAE Motor Eaton	2
54	40040	Adapter JIC/BSPP Motor Adan/Danfoss	2
55	42077	Bonded Seal BSPP Adan/Danfoss	2
56	111E-0604	Adapter Case Drain Eaton	1
56	111Q-0604	Adapter Case Drain Adan/Danfoss	1
57	29F-01	Grease Fitting	1
58	C-21088	Coneqtec Decal	1
59	C-21076	APX 300 Model Decal	1
59	C-21077	APX 400 Model Decal	1
59	C-21078	APX 450 Model Decal	1
59	C-21079	APX 600 Model Decal	1
60	80443	General Caution Decal	1
61	80440	Danger Rotating Decal	3
62	C-21080	Power Adjustment Decal	2
63	C-21081	APX Depth Decal	1
64	80441	Slide Pinch Warning Decal	1
65	251747A1	Visual Pinch Warning Decal	2
66	55513	Pinch Warning Decal	2
67	40069	Pic Tool	1
68	55384	Adan MVA Seal Kit (Ref: Item 4)	AR
68	55511	Eaton 6000 Seal Kit (Ref: Item 4)	AR
68	52829	Danfoss OMV Seal Kit (Ref: Item 4)	AR
69	55548	Belleville Washer	8

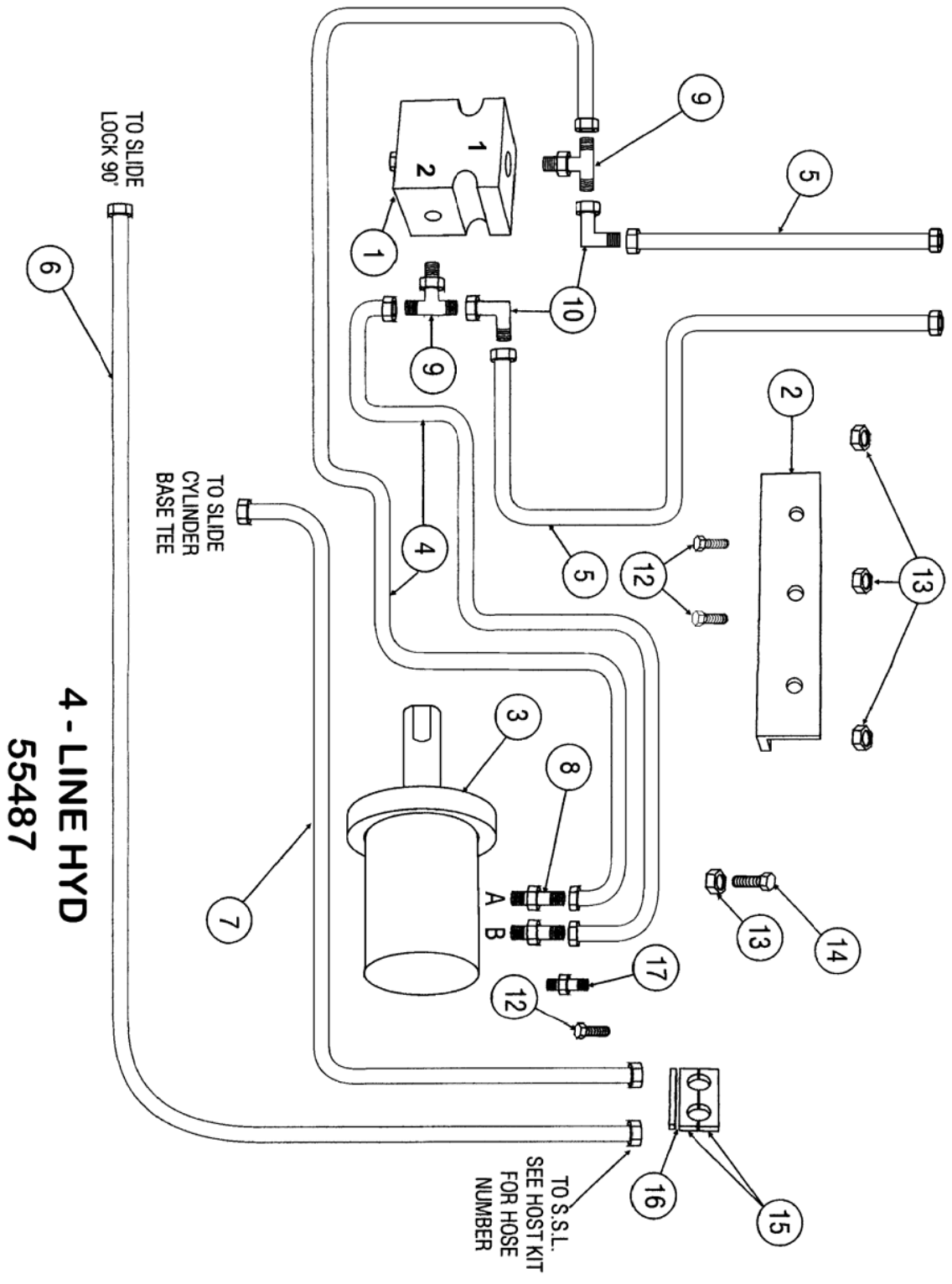

4 LINE APX HYD PARTS LIST 55487

ITEM	P/N	DESCRIPTION	QTY
1	54545	Cartridge for 55344	1
1	55344	Overrunning Valve	1
1	56049	Seal Kit O.R. Valve	1
2	55463	O.R. Valve Bracket	1
3		Motor - (See Motor Size Table)	1
4	54723	Hose 3/4" x 52" Motor	2
5*		Hose 3/4" TO S.S.L.	2*
6*		Hose 1/4" Slide	1*
7*		CylinderHose 1/4" Slide Cylinder	1*
8	40040	Adapter Motor - Adan/Danfoss SAEM / BSPP	2
8A	42077	Bonded Seal - Adan/Danfoss	2
8	111E-1216	Adapter Motor - Eaton JICM / SAEM	2
9	111C-1212	Adapter Tee JICM / SAEM	2
10	112B-12	Adapter 90° JICF / JICM	2
11	50A-0516	5/16-18 x 2 HHCS	1
12	50A-0522	5/16-18 x 2-3/4 HHCS	2
13	30C-05	5/16-18 Nylock Nut	5
14	50A-0510	5/16-18 x 1-1/4 HHCS	2
15	54047	Hose Clamp 1/4 (Pair)	1
16	54048	Hose Clamp Plate	1
17	111E-0604	Adapter Case Drain Eaton	1
17	111Q-0604	Adapter Case Drain Adan/Danfoss	1

* HOSES WILL DEPEND ON WHICH S.S.L.
THE PLANER IS ON. SEE HOST KIT FOR THAT LOADER.

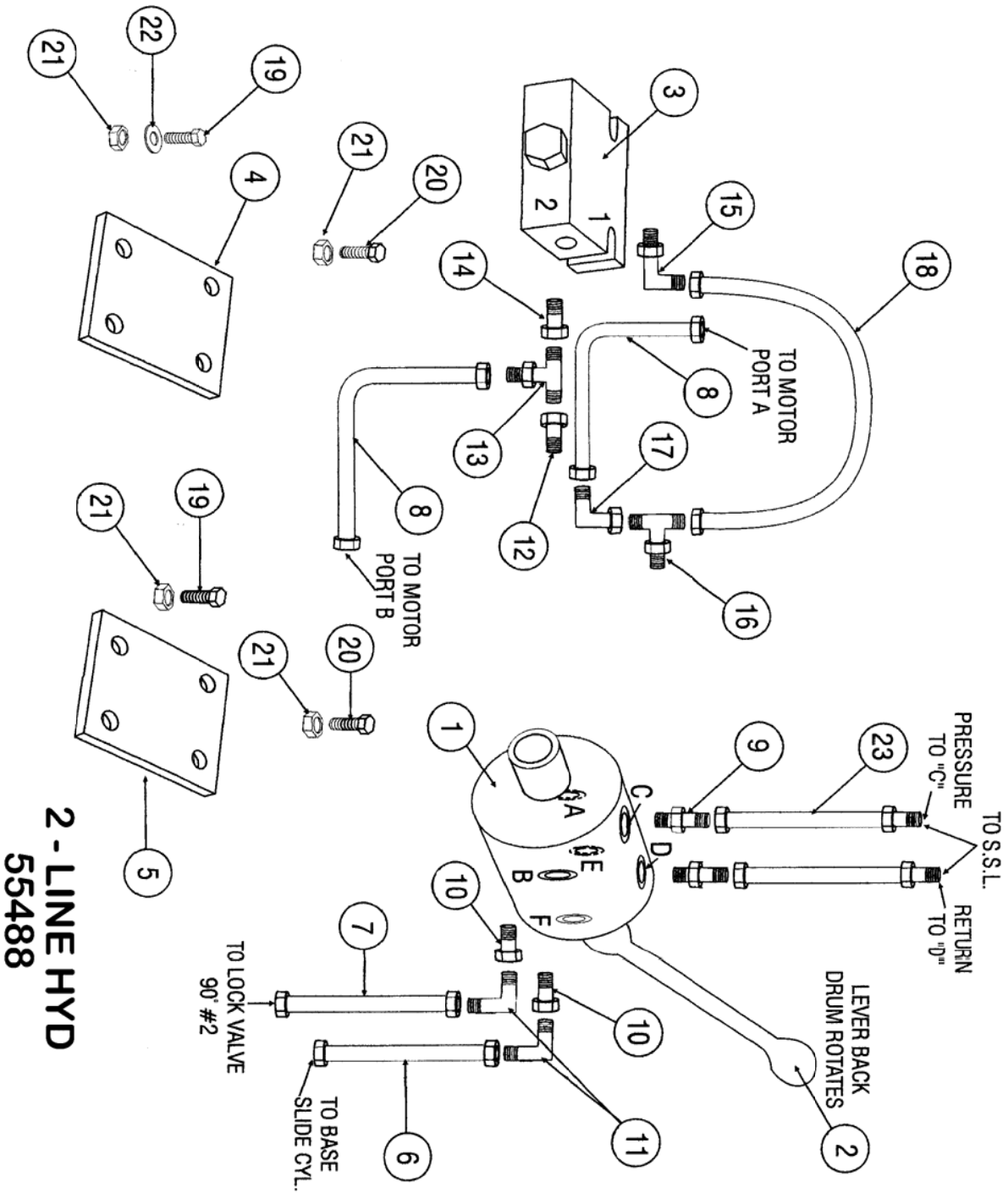

2 LINE APX HYD PARTS LIST 55488

ITEM	P/N	DESCRIPTION	QTY
1	55977	Detent Kit	AR
1	55472	Selector Valve	1
1	56050	Seal Kit Selector Valve	1
2	55483	Lever	1
2	55621	Lever Link Kit	1
3	55344	Overrunning Valve	1
3	56049	Seal Kit O.R. Valve	1
3	54545	Cartridge for 55344	1
4	55481	O.R. Valve Bracket	1
5	55480	Selector Valve Bracket	1
6	54026	Hose 1/4 x 15"	1
7	55482	Hose 1/4 x 35"	1
8	54723	Hose 3/4 x 52" Motor Pressure / Return	2
9	110G-1216	Adapter Str JICM/NPTM	2
10	115B-1608	Adapter Reducer NPTF/NPTM	2
11	110R-0408	Adapter 90° JICM / NPTM	2
12	115B-1612	Adapter Reducer NPTF/NPTM	1
13	110AH-1212	Adapter Tee JICM/NPTM	1
14	111V-12	Adapter Str SAEM/NPTF	1
15	111B-1212	Adapter 90° JICM/SAEM	1
16	110Y-1216	Adapter Tee JICM/NPTM	1
17	112B-12	Adapter 90° JICM/JICF	1
18	55479	Tube Assy 3/4" x 180°	1
19	50A-0522	5/16-18 x 2-3/4 HHCS	4
20	50A-0510	5/16-18 x 1-1/4 HHCS	4
21	30C-05	5/16-18 Nylock Nut	8
22	14C-05	5/16 Flat Washer	2
23*		Hose 3/4" TO SSL	2

* HOSES WILL DEPEND ON WHICH S.S.L.
PLANER IS ON. SEE HOST KIT FOR THAT LOADER.

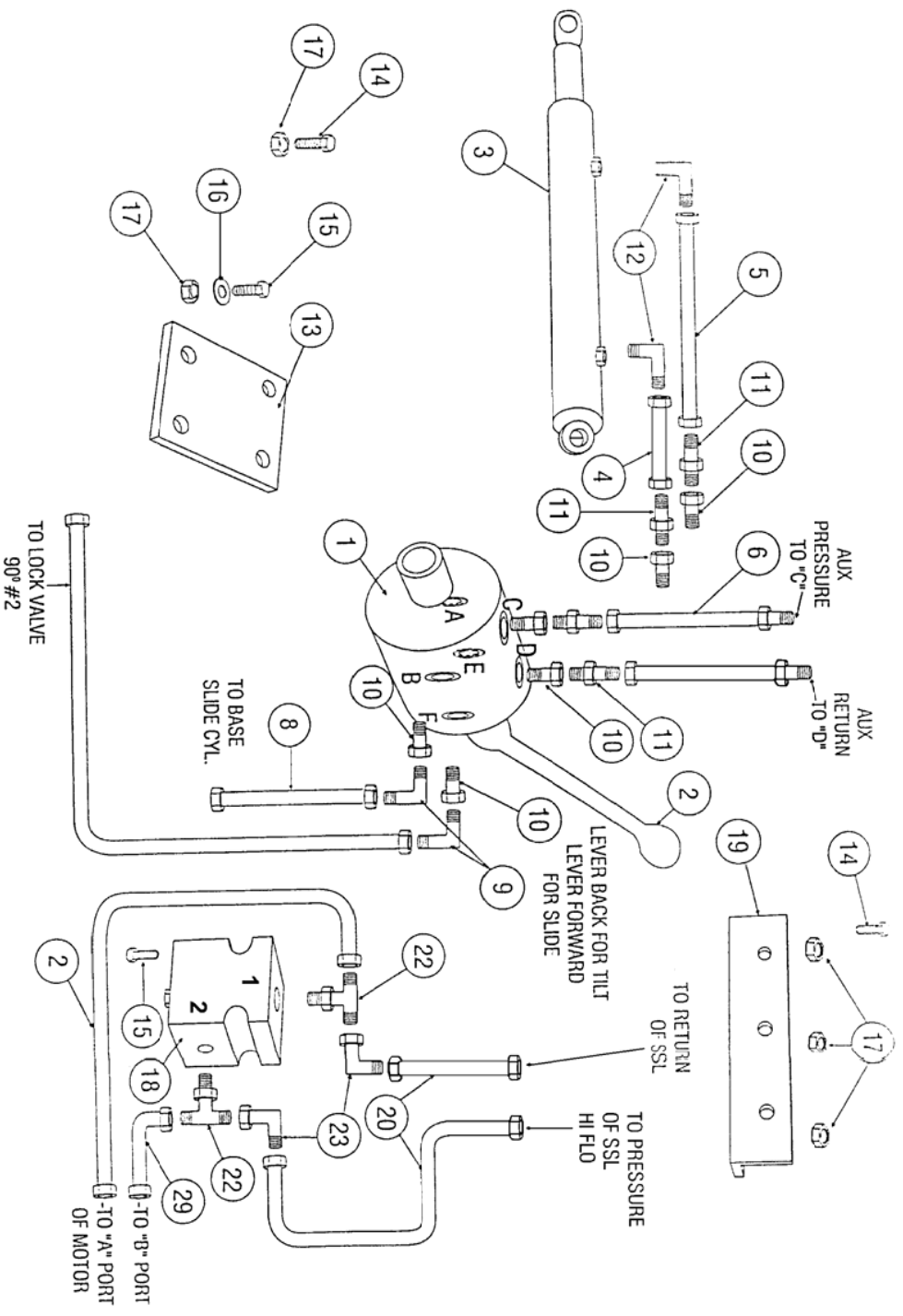

**4 - LINE HYD WITH OPTIONAL TILT
55489**

4 LINE APX HYD AUX WITH TILT AND SLIDE 55489

ITEM	P/N	DESCRIPTION	QTY
1	55472	Selector Valve	1
1	56050	Seal Kit Selector Valve	AR
2	55483	Lever	1
2	55621	Lever Link Kit	1
3	54066	Tilt Cylinder	1
3	55033	Cylinder Seal Kit	AR
4	54028	Hose 1/4 x 51" Tilt Base	1
5	55485	Hose 1/4 x 57" Tilt Rod	1
6*		Hose 1/4" TO SSL	2
7	55482	Hose 1/4 x 35" Lock Valve 90 #2	1
8	54026	Hose 1/4 x 15" Base	1
9	110R-0408	Adapter 90° JICM/NPTM	2
10	115B-1608	Adapter Reducer NPTM/NPTF	6
11	110G-0408	Adapter Str JICM/NPTM	4
12	110R-0404	Adapter 90° JICM/NPTM	2
13	55480	Selector Valve Bracket	1
14	50A-0510	5/16-18 x 1-1/4 HHCS	2
15	50A-0522	5/16-18 x 2-3/4 HHCS	2
16	14C-05	5/16 Flat Washer	2
17	30C-05	5/16-18 Nylock Nut	4
18	55344	Overrunning Valve	1
18	56049	Seal Kit O.R. Valve	AR
18	54545	Cartridge for 55344	1
19	55463	O.R. Valve Bracket	1
20*		Hose 3/4" TO SSL	2
21	54723	Hose 3/4" x 52" Motor	2
22	111C-1212	Adapter Tee JICM/SAEM	2
23	112B-1212	Adapter 90° JICM/JICF	2

* HOSES WILL DEPEND ON WHICH S.S.L.
THE PLANER IS ON. SEE HOST KIT FOR THAT LOADER.

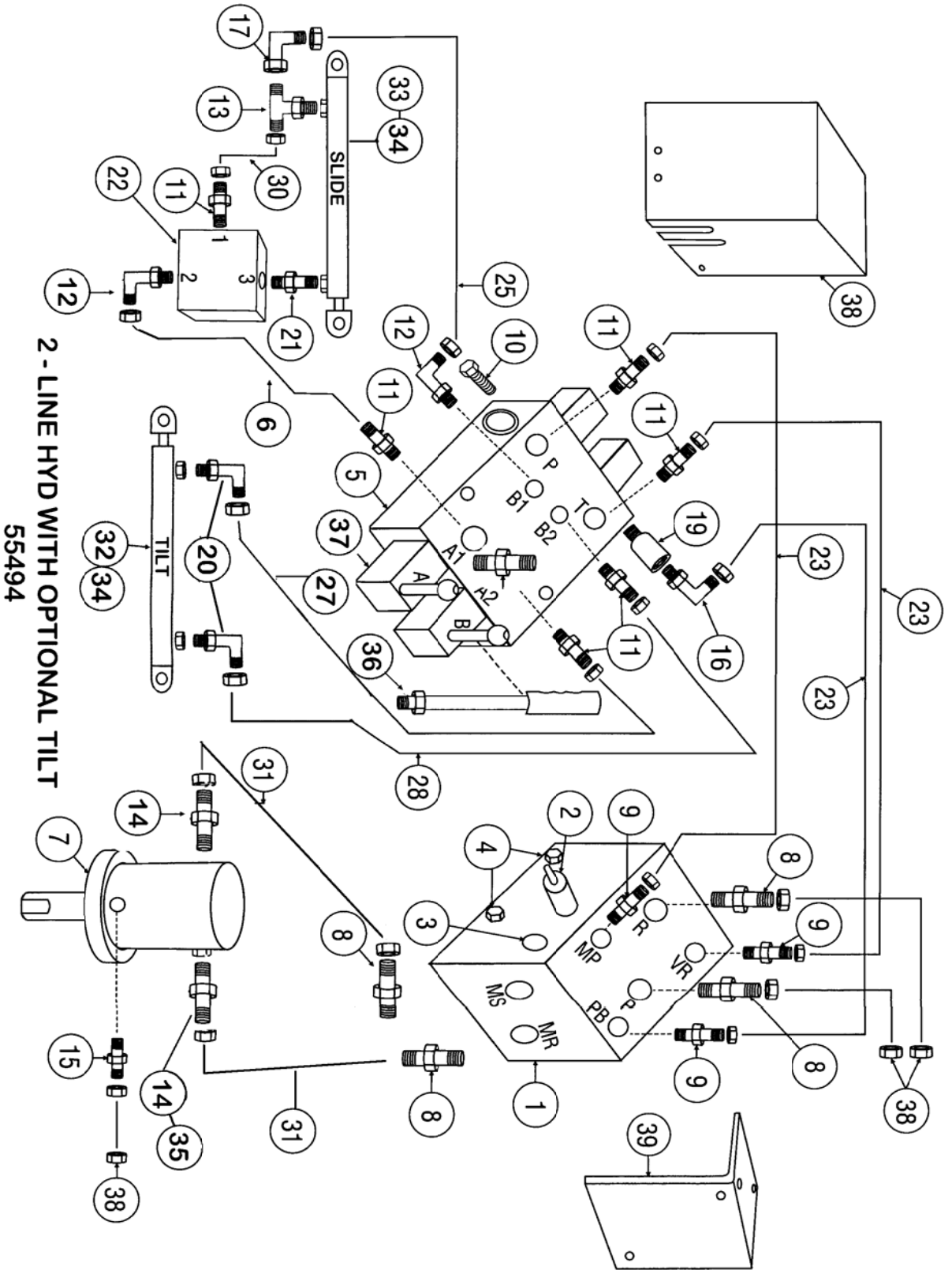

2 - LINE HYD WITH OPTIONAL TILT
 55494

2 LINE APX HYD AUX WITH TILT AND SLIDE 55494

ITEM	P/N	DESCRIPTION	QTY
1	55140	Valve Assy (Inc. 1,2,3,4)	1
1	55277	Seal Kit for 55140 Valve	AR
1	55229	Valve Block Only	1
2	55232	Priority Valve 2 gpm	1
3	55231	Check Valve PB	1
4	55230	Check Valve Anti Cav & Return	2
5	55228	BLB Spool Valve	1
5	55928	Spool Seal BLB	4
6	55177	Hose Slide Rod End 78"	1
7	See Spec	Motor	1
8	111E-1212	Adapter	4
9	111E-0404	Adapter	3
10	111HH-08	SAE Plug Socket Head	1
11	111E-0406	Hyd Adapter JIC/SAE Str	6
12	111B-0406	Hyd Adapter JIC/SAE 90°	2
13	110Y-0404	Hyd Adapter JIC/NPT Tee	1
14	40040	Hyd Adapter JIC/BSPP OMV	2
15	111Q-0604	Adapter Case Drain Danfoss	1
16	111B-0408	Hyd Adapter 90° JIC/SAE	1
17	112B0404	Hyd Adapter JIC/JIC	1
19	55259	Power Beyond Sleeve	1
20	110R-0404	Hyd Adapter JIC/NPT 90°	2
21	111K-0604	Hyd Adapter SAE/NPT Str	1
22	52981	Lock Valve	2
22	54946	Seal Kit 53981 Valve	AR
23	55178	Hose VP-P/T-VR 51"	3
25	55176	Hose Slide Base End 63"	1
27	55175	Hose Tilt Cyl Rod Depth Tee 106"	1
28	55173	Hose Tilt Cyl Base 112"	1
30	54114	Hose Slide Pilot 25"	1
31	54723	Hose Motor 52" 3000 PSI	2
31	55539	Hose Motor 52" 5000 PSI	2
32	54066	Tilt Cylinder	1
33	54064	Slide Cylinder	1
34	55033	Seal Kit Cylinder	AR
35	42077	Bonded Seal OMV Motor	2
36	55279	Lever	AR
37	55612	Pivot Box	AR

SWINGAWAY ARM ASSEMBLY

ITEM #	PART #	DESCRIPTION	QTY
1	55264	Valve Cover	1
2	55228	BLB Spool Valve	1
3	55531	Sliding Arm	1
4	54736	Horizontal arm	1
5	15003	Knob	1
6	54735	Vertical Arm	1
7	54734	Lower Bracket	1
8	50A-0624	3/8" x 3" HHCS	2
9	30C-06	3/8" Nyloc Nuts	2
10	50A-0422	1/4" x 2 3/4" HHCS	2
11	30C-04	1/4" Nyloc Nuts	2
12	10C-0424	1/4" x 3" Clevis Pin	2

** 54730 SWINGAWAY KIT—ALL ITEMS ABOVE

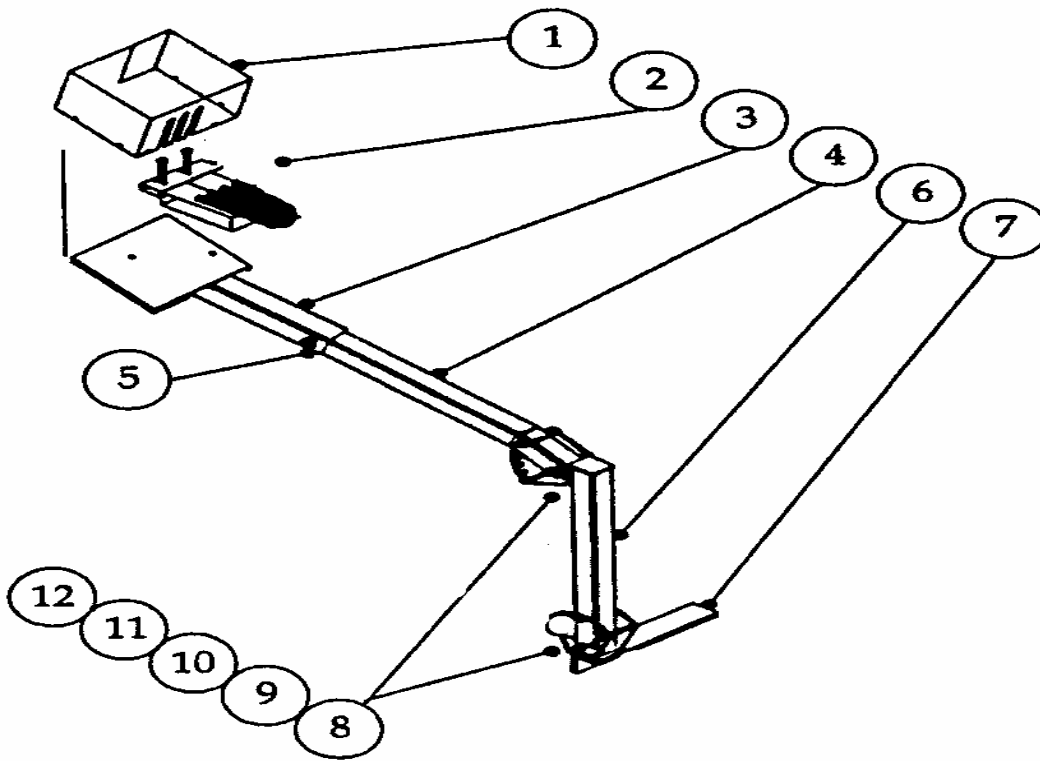

APX HOST KITS

55465X BOBCAT HI FLO APX/SSG HOST KIT

Part #	Description	Qty
55900	3/4 x 72" Hose	2
55174	1/4 x 106" Hose	1
55476	1/4 x 125" Hose	1
54136	3/8 x 106" Case Drain Hose	1
111E-0608	Case Drain QC Adapter	1
111E-1212	Adapter	2
111E-0408	Adapter	2

55465XT BOBCAT HI FLO APX W/TILT HOST KIT

Part #	Description	Qty
55900	3/4 x 72" Hose	2
55486	1/4 x 90" Hose	2
54136	3/8 x 106" Case Drain Hose	1
111E-0608	Case Drain QC Adapter	1
111E-1212	Adapter	2
111E-0408	Adapter	2

55466X CASE-GEHL-MUSTANG-TRAK-THOMAS APX/SSG7 HOST KIT

Part #	Description	Qty
55524	3/4 x 100" Hose	2
55477	1/4 x 62" Hose	1
55478	1/4 x 80" Hose	1
54822	3/8 x 157" Case Drain Hose	1
111E-1212	Adapter	2
111E-0408	Adapter	2
111E-0610	(Case)	1
111E-0608	(Gehl, Mustang)	1
11OG-0608	(Thomas)	1

APX HOST KITS (Cont.)

55466XT CASE-GEHL-MUSTANG-TRAK-THOMAS WITH

UNIVERSAL Q.A. & HI FLO APX/W TILT

Part #	Description	Qty
55524	3/4 x 100" Hose	2
55608	1/4 x 72" Hose	2
54822	3/8 x 157" Case Drain Hose	1
111E-1212	Adapter	2
111E-0408	Adapter	2
111E-0410	(Case)	2
111E-0610	(Case)	1
111E-0608	(Gehl, Mustang)	1
11OG-0608	(Thomas)	1

55469XH JCB HI FLO APX/SSG7 HOST KIT

Part #	Description	Qty
55524	3/4 x 100" Hose	2
55174	1/4 x 106" Hose	1
55476	1/4 x 125" Hose	1
54822	3/8 x 157" Case Drain Hose	1
40040	Adapter	2
111Q-0406	Adapter	2
111Q-0608	Case Drain QC Adapter	1

55469XHT JCB HI FLO APX W/TILT HOST KIT

Part #	Description	Qty
55524	3/4 x 100" Hose	2
55486	1/4 x 90" Hose	2
54822	3/8 x 157" Case Drain Hose	1
40040	Adapter	2
111Q-0406	Adapter	2
111Q-0608	Case Drain QC Adapter	1

APX HOST KITS (Cont.)

55469L JCB LO FLO HOST KIT AP/APX

Part #	Description	Qty
55524	3/4 x 100" Hose	2
111Q-1212	Adapter	2

32767 NEW HOLLAND-JOHN DEERE, AP/APX /SSG7 HOST KIT

Part #	Description	Qty
55900	3/4 x 72" Hose	2
54822	3/8 x 157" Case Drain Hose	1
111E-1212	Adapter	2
111E-0608	Case Drain QC Adapter	1

55495 LOW FLO (2-LINE) HOST KIT AP/APX Q.C. ON LH BOOM ARM, UNIVERSAL Q.A.

Part #	Description	Qty
55900	3/4 x 72" Hose	2
111E-1212	Adapter	2

55665X CAT 248 HOST KIT-APX & SSG7

Part #	Description	Qty
55902	3/4 x 72" Hose	2
55486	1/4 x 90" Hose	1
55174	1/4 x 106" Hose	1
54170	3/8 x 125" Case Drain Hose	1
111E-1212	Adapter	2
111E-0608	Adapter	1
111E-0408	Adapter	2

APX HOST KITS (Cont.)

55665XT

CAT 248 APX W/TILT

Part #	Description	Qty
55902	3/4 x 72" Hose	2
55608	1/4 x 72" Hose	2
54170	3/8 x 125" Case Drain Hose	1
111E-1212	Adapter	2
111E-0608	Adapter	1
111E-0408	Adapter	2

55704X

CASE APX & SSG 5000 PSI

Part #	Description	Qty
55538	3/4 X 100" Hose	2
55486	1/4 x 90" Hose	1
55174	1/4 x 106" Hose	1
54822	3/8 x 157 Case Drain Hose	1
111E-1212	Adapter	2
111E-0610	Adapter	1
111E-0410	Adapter	2

55704XT

CASE APX W/TILT 5000 PSI

Part #	Description	Qty
55538	3/4 X 100" Hose	2
55608	1/4 x 72" Hose	2
54822	3/8 x 157 Case Drain Hose	1
111E-1212	Adapter	2
111E-0610	Adapter	1
111E-0410	Adapter	2

DANFOSS MOTOR OMV PARTS LIST

ITEM	P/N	DESCRIPTION	QTY	ITEM	P/N	DESCRIPTION	QTY
1	52676	Screw M8x1x20mm	6	26	52694	Channel Plate	1 NSS
2	52677	Dust Deal Ring	1	28	52695	Disc Valve	1 NSS
3	52678	Front Cover	1	29	52969	Balance Plate	1 NSS
4	52679	Shaft Seal	1	30	52697	Guide Pin	1 NSS
5	52680	O Ring	1	31	52698	O Ring	1
6	52681	Parallel Key	1	32	52699	O Ring	1
7	52682	Shaft Including Bearing	1	33	52700	Spacer	1 NSS
8	52683	Conical Seal Ring	1	34	52701	Spring Washer	1 NSS
9	52684	Bearing Housing	1	36	52702	Valve Housing	1 NSS
10	52685	Drain Plug Including O Ring	1	37	52703	Ball	2 NSS
13	52687	Cardan Shaft for 52708 500 mtr	1 NSS	38	52704	Springs	2 NSS
13	55333	Cardan Shaft for 52588 630 mtr	1 NSS	39	52705	Washers	2 NSS
13	55334	Cardan Shaft for 54329 800 mtr	1 NSS	40	52706	Plugs	2 NSS
22	52689	O Ring	1	41	52707	Cap Screw OMV500 & 630	4 NSS
23	52690	Gearwheel set for 52588 630mtr	1 NSS	41	55335	Cap Screw for 54329 800mtr	4 NSS
23	52691	Gearwheel set for 52708 500mtr	1 NSS	42	55254	Name Plate OMV	1 NSS
23	55332	Gearwheel set for 54329 800mtr	1 NSS	43	54930	Drive Screw	4 NSS
24	52692	Guide Pin	1 NSS	44	52829	Seal Kit OMV Includes items 2,4,5,8,22,31,32	1
25	52693	Valve Drive	1 NSS				

NOTE: NSS— NOT SERVICED SEPARATELY

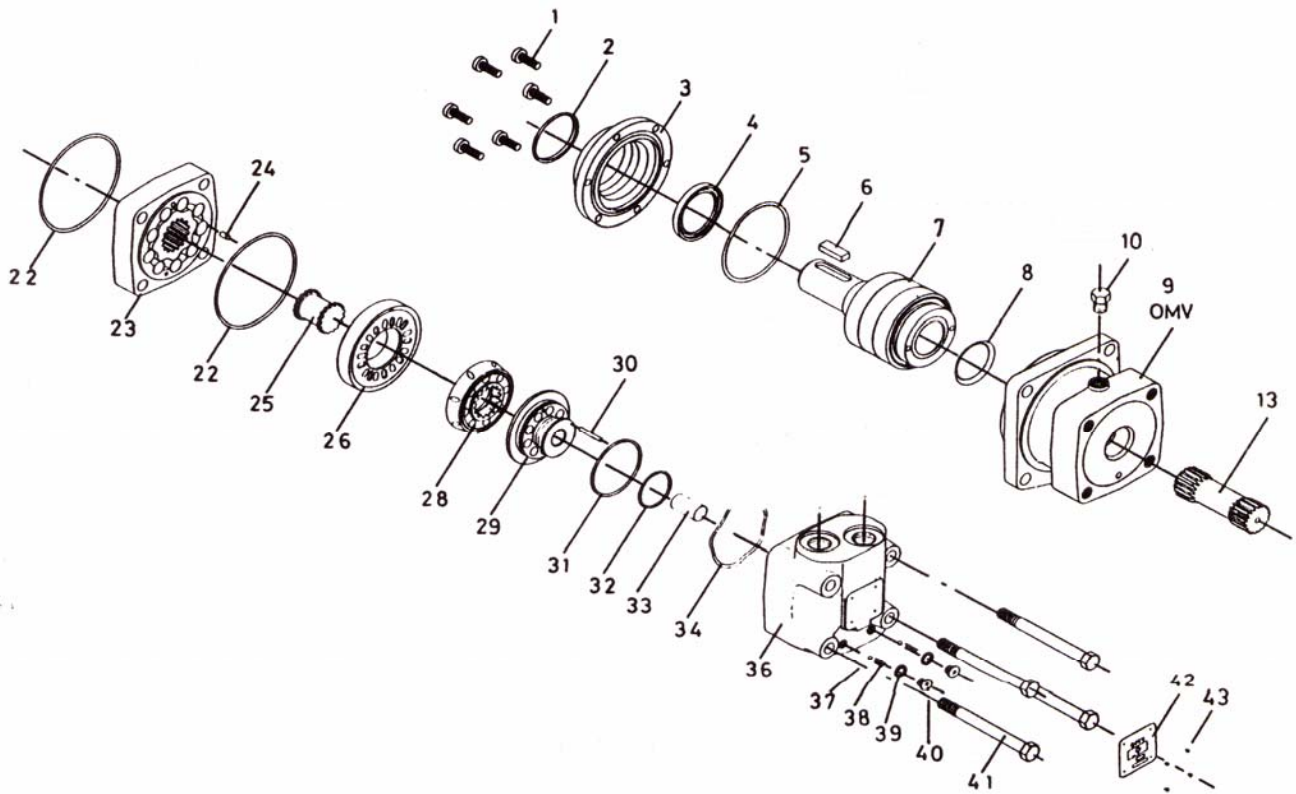



P/N 56045

3348 S. Hoover • Wichita, KS 67215 • 316-946-5885